

**TOWN OF HEBRON
HES DRINKING WATER REMEDIATION BUILDING COMMITTEE
SPECIAL MEETING**

HES DRINKING WATER REMEDIATION BUILDING COMMITTEE

Weds, Jul 8, 2020 5:00 PM -- 6:00 PM (EDT)

Please join my meeting from your computer, tablet or smartphone.

<https://global.gotomeeting.com/join/322485493>

You can also dial in using your phone.

(For supported devices, tap a one-touch number below to join instantly.)

United States: +1 (571) 317-3122

- One-touch: [tel:+15713173122,,322485493#](tel:+15713173122,322485493#)

Access Code: 322-485-493

RECEIVED

200 JUL -7 P 1:03
HEBRON TOWN CLERK

Agenda

Wednesday July 08, 2020

5:00 PM

- 1) CALL TO ORDER
- 2) PLEDGE OF ALLEGIANCE
- 3) PUBLIC COMMENT

This section of the agenda is reserved for persons in attendance who wish to briefly address the HES Drinking Water Remediation Building Committee. The committee requests that comments be limited to three minutes or less. Persons wishing to address the Committee regarding agenda items should request clarification from the Chair as to whether or not they should speak during the public comment portion of the meeting or at the time the agenda item is considered

- 4) **CONSENT AGENDA (APPROVAL OF MINUTES)**
 - a) Special meeting minutes 06-22-2020
 - b) Regular meeting minutes 06-15-2020 (pending)
 - c) Previous Meeting SP&A notes 06-15-2020

5) REVIEW SILVER PETRUCELLI – NUTMEG COMPANIES

- a) Project Status (abatement, Demo, reconstruction)
 - (1) Additional costs Fuss & O'Neil
- b) Submittals
- c) Change Order

6) REVIEW STATUS OF APPROVED CHANGE ORDERS

- a) Change Order #1
 - i) PCO #1 Additional test points per DPH
 - ii) PCO #3 Add Drinking Fountain to Music Room 93
 - iii) PCO #4 Replace cracked fixtures PR #2

7) CONSIDER AND ACT ON POTENTIAL CHANGE ORDERS

- a. PCO #5 Remove replace Ceiling tiles \$9,599
- b. PCO #6 Replace Kitchen Sink Faucets \$3,421

8) PAYMENT REQUISITIONS

- a) Consider and Act on Approved Requisitions:
 - i) MMFC Inv #6 \$8982.50
 - ii) Hungerfords Inv # 86775 \$575.00
 - iii) Nutmeg Req #4 \$191,889.69

9) ADJOURNMENT

**TOWN OF HEBRON
HES DRINKING WATER REMEDIATION BUILDING COMMITTEE
SPECIAL MEETING**

HES DRINKING WATER REMEDIATION BUILDING COMMITTEE
Weds, Jul 8, 2020 5:00 PM - 6:00 PM (EDT)

Please join my meeting from your computer, tablet or smartphone.

<https://global.gotomeeting.com/join/322485493>

You can also dial in using your phone.
(For supported devices, tap a one-touch number below to join instantly.)

United States: +1 (571) 317-3122
- One-touch: <tel:+15713173122,,322485493#>

Access Code: 322-485-493

Agenda

Wednesday July 08, 2020

5:00 PM

1) CALL TO ORDER

2) PLEDGE OF ALLEGIANCE

3) PUBLIC COMMENT

This section of the agenda is reserved for persons in attendance who wish to briefly address the HES Drinking Water Remediation Building Committee. The committee requests that comments be limited to three minutes or less. Persons wishing to address the Committee regarding agenda items should request clarification from the Chair as to whether or not they should speak during the public comment portion of the meeting or at the time the agenda item is considered

4) CONSENT AGENDA (APPROVAL OF MINUTES)

- a) Special meeting minutes 06-22-2020
- b) Regular meeting minutes 06-15-2020 (pending)
- c) Previous Meeting SP&A notes 06-15-2020

5) REVIEW SILVER PETRUCELLI – NUTMEG COMPANIES

- a) Project Status (abatement, Demo, reconstruction)
 - (1) Additional costs Fuss & O'Neil
- b) Submittals
- c) Change Order

6) REVIEW STATUS OF APPROVED CHANGE ORDERS

- a) Change Order #1
 - i) PCO #1 Additional test points per DPH
 - ii) PCO #3 Add Drinking Fountain to Music Room 93
 - iii) PCO #4 Replace cracked fixtures PR #2

7) CONSIDER AND ACT ON POTENTIAL CHANGE ORDERS

- a. PCO #5 Remove replace Ceiling tiles \$9,599
- b. PCO #6 Replace Kitchen Sink Faucets \$3,421

8) PAYMENT REQUISITIONS

- a) Consider and Act on Approved Requisitions:
 - i) MMFC Inv #6 \$8982.50
 - ii) Hungerfords Inv # 86775 \$575.00
 - iii) Nutmeg Req #4 \$191,889.69

9) ADJOURNMENT

TOWN OF HEBRON
HES DRINKING WATER REMEDIATION BUILDING COMMITTEE
SPECIAL MEETING – JUNE 22, 2020
VIDEO CONFERENCE

Members Present: M. Leichter, R. Steiner, D. Foster, W. Warwick, H. Petit

Staff Present: T. Baird

The special meeting was called to order at 7:01 a.m.

Public Comment: None.

CONSIDER AND POSSIBLY ACT ON CHANGE ORDER #2: M. Leichter state that PCO #5 (if approved would be Change Order #2) is for \$9,599. It is for SP&A to provide the labor and material to remove and stare the ceiling Tiles in all hallways and a row of ceiling tiles in each of the 1936 classrooms on the wall that borders the hallway. The purpose of this activity is to provide visual access to the fire wall areas to determine the amount of work needed to be done, and to receive a fixed cost, to seal all firewall penetrations that were not sealed properly from PREVIOUS projects.

Discussions were have regarding the request for this PCO. It was supposed to be provided in a detailed manner but was returned for approval with no details. D. Foster stated that he believe the number of hours was to high and he suspected the prevailing wage hourly was not that of a laborer but may have been for a skilled tradesman,

D. Foster moved and W. Warwick seconded a motion to Approve CO #2. The motion failed with no members voting aye and 5 voting no. The committee request M. Leichter to go back to SP&A and request then to review and address the concerns with Nutmeg Companies.

CONSIDER EARLY ACTIVATION OF THE NEW WATER DISTRIBUTION SYSTEM: M. Leichter stated that Nutmeg had requested permission to turn on the water in the new water distribution system. This was asked because the contract specifies that all work must be complete prior to activating the new system. Nutmeg's request was made so that the system could be flushed for a longer period prior to state DPH testing and so they could follow up their air pressurization tests with actual water in the system. They assured the committee that all previous piping was disconnected from the building water source.

SP&A does not support this request. The committee discussed the plusses and minuses of this request. Although several members agree this would be a positive activity R. Steiner pointed out that to do this without SDP&A's support could lead to further issues as the project progressed. The committee agreed and decided not to act on this request. They asked M. Leichter to ask why the did not support the activity.

With no further business to discuss D. Foster moved and R. Steiner seconded a motion to adjourn the meeting. The motion passed unanimously and the meeting was adjourned at 7:42 a.m.

Respectfully submitted,
Mal Leichter; Chairman



Meeting Minutes

Project: Hebron Elementary School – Contaminated Water Piping Replacement

Client: Town of Hebron
15 Gilead Street
Hebron, CT 06248

Location: GoToMeeting Video Conference

Date: June 15, 2020 at 6:30 pm

Attendees:

Mal Leichter	Hebron BC Chair	mleichter@hebronct.com
David Foster	Hebron BC	nilrem@sbcglobal.net
Heather Petit	Hebron BC/BOE	hrpetit@gmail.com
Richard Steiner	Hebron BC	rsteiner183@aol.com
Wayne Warwick	Hebron BC	wwarwick31@gmail.com
John Collins	Hebron Board of Selectmen	jcollins@hebronct.com
Tom Baird	Hebron Public Schools	tbaird@hebron.k12.ct.us
Michael Larkin	Hebron Public Schools	mlarkin@hebron.k12.ct.us
Wayne Durocher	Hebron Public Schools	wdurocher@hebron.k12.ct.us
Kaitlynn O’Leary	Hebron Public Schools	koleary@hebron.k12.ct.us
Mark FitzGerald	Clerk of the Works	fitz51160@yahoo.com
Evert Gawendo	The Nutmeg Companies	evert@nutmegcompanies.com
Ryan Haley	Silver/Petrucci+Associates	rhaley@silverpetrucelli.com

Purpose:

Regular Meeting of the HES Drinking Water Remediation Building Committee to review project status.

Meeting Notes:

1. Meeting start time 6:33pm
2. John Collins spoke about his coordination with UCONN to collect samples of the contaminated piping throughout HES for research purposes.
3. Hebron BoE provided a brief update regarding the end of school and the partial reimbursement received from DAS.

4. Clerk of the Works Report:

- 4.1. Mark FitzGerald (MF) provided a brief update based on his return to regular site visits on 6/15.
- 4.2. MF noted concerns regarding Nutmeg's field decision to limit demolition of existing plumbing chase walls at Male Toilet #95. RH informed MF that Nutmeg's decision is a matter of Means & Methods. RH noted that if Nutmeg is able to complete the required piping Work without needing to remove the full scope of wall construction shown on the drawings to be removed, that is Nutmeg's decision to make and something that S/P+A will review in the field. Any changes to the work will be evaluated by S/P+A to determine if said changes warrant a credit back to the Owner.
- 4.3. MF requested the committee's approval to make field decisions and provide direction to Nutmeg on behalf of the Owner. RH expressed concern with this proposition, as Nutmeg should only be taking direction from S/P+A in conjunction with the Owner. RH extended an open invitation for MF to reach out to RH or SJ to discuss any concerns he may have about the work to keep things moving smoothly. Mal Leichter (ML) noted (with concurrence from other committee members) that Nutmeg should only take direction from S/P+A in order to follow the proper chain of communication.

5. S/P+A / Nutmeg Project Status Update:

- 5.1. Nutmeg remobilized on site today (Monday 6/15/20) and began demolition work at Toilet 95.
- 5.2. Steve June (SJ) is working to coordinate weekly site visits on Thursday mornings at 11:30am, resuming on Thursday 6/18/20. ML & WD confirmed that this day & time works for them. EG recommended meeting at HES to review field conditions.
- 5.3. Nutmeg is working to prepare Change Order Proposals for the temp ceiling removal & firestopping work under PR-04 & PR-05, expects to have them ready to submit this week.
- 5.4. EG asked if it might be possible to connect the new domestic water piping to the well source to start flushing the lines as work progresses. EG stated that the new piping work is completely isolated from the old work, and would not be connected to any old work. Bid Addendum #5 states that the Contractor is required to, "...*completely install, test and start-up the new domestic water system in it's entirety and to completion before connection to the existing domestic water well source piping.*" RH stated that S/P+A would be open to discussing some relief to this requirement.

6. Payment Requisitions:

- 6.1. BC approved payment of S/P+A invoice #20-1274 along with an invoice from MMFCLLC, Hungerford's & Jacobson.

7. Other Business:

- 7.1. Richard Steiner (RS) asked RH if DAS requires bond premiums be charged as a separate Change Order at the end of construction, or if it's acceptable to include the increased premiums under each CO along the way. RS noted that he's seen it done both ways depending on the entity. RH will research & provide update.
 - 7.1.1. Post-Meeting Update: Per RH review of the Contract, bond premium costs are included in the 15% OH&P markup allowance per Article 7.5.1 of the Supplementary General Conditions, a separate charge for bond premium increases is not required.
- 7.2. RS requested on behalf of the Committee that Steve June (SJ) resume regular appearances at the building committee meetings to provide regular project updates as he will continue to be S/P+A's on-site representative. RS stated that it would be acceptable to the Committee to bump SJ's up in the agenda so he could give his 10-15 minute update and depart the meeting. RH will relay this request to SJ. RH noted that SJ's absence from recent meetings is due in large part to a scheduling conflict with one

of SJ's other projects that hold meetings on the same regular schedule as Hebron, but limiting the amount of SJ's time at each Hebron meeting would certainly help ease the conflict.

8. Next meeting will be Monday *TBD* at 6:30pm.
9. Meeting adjourned at 7:56pm.

Any corrections, additions or comments regarding the above meeting minutes must be submitted in writing to Silver/Petrucci + Associates within 14 days of the issue date noted below.

Minutes Prepared By: Ryan Haley, S/P+A

Minutes Issued: June 16, 2020

Distribution: Meeting attendees, S.June, K.Eldridge, W.Silver, S/P+A File.

THE NUTMEG COMPANIES, INC.

PROPOSAL/ESTIMATE FOR CONTRACT MODIFICATION

CONTRACT TITLE: Hebron School Contaminated Water Piping Replacement

DATE: 6/16/2020

CONTRACT #

Rev Date:

PCO #05 Remove & Replace Ceilings per PR#4

DESCRIPTION OF PROPOSAL: Remove & replace ceilings per PR#4 to allow access for a survey for existing penetration violations of rated corridor walls.

PRIME CONTRACTOR'S WORK			
1. Direct Materials		\$350.00	
2. Sales Tax on Materials 0 % of line 1	0.00%	\$0.00	
3. Direct Labor		\$7,996.80	
4. Misc. / Rental Equipment Crane / Lull Rental		\$0.00	
5. Sales Tax on Rental Equipment 6.35% of line 4	6.35%	\$0.00	
6. Equipment Ownership and Operating Expenses			
7. SUBTOTAL (add lines 1 - 6)			\$8,346.80
8. Field Overhead	0.00%		\$0.00
9. SUBTOTAL			\$8,346.80

Prime Remarks:

SUBCONTRACTOR'S WORK			
10. Subcontractor's work			\$0.00
11. Sub-contractors Bond Premium ___% of line 10	0.00%		\$0.00
12. SUBTOTAL			\$0.00

Sub's Remarks:

SUMMARY			
13. Prime Contractor's Work (from line 9)		\$8,346.80	
14. Not used		\$0.00	
15. Not Used		\$0.00	
16. Sub-contractor's Work (from line 12)		\$0.00	
17. SUBTOTAL (add lines 13, 14, 15 & 16)			\$8,346.80
18. Prime Overhead on Sub. 13.1.74% of line 16	5.00%	\$0.00	
19. Prime's Overhead 10% of line 13	10.00%	\$834.68	
20. Prime's Profit 5 % of line 17	5.00%	\$417.34	
21. SUBTOTAL (add lines 16, 17, 18, 19 & 20)			\$9,598.82
22. Prime Cont.'s Bond Premium	0.000%	\$0.00	
23. TOTAL COST (Add Lines 21 & 22)			9,599

Estimated time extension and justification:

Prime Contractor Name: THE NUTMEG COMPANIES, INC.

DESCRIPTION OF PROPOSAL: Remove & replace PCO #05 Remove & Replace Ceilings per PR#4

DATE: 6/16/2020

QTY	DESCRIPTION	Unit	UNIT MATERIAL	TOTAL MATERIAL	UNIT HRS.	HOURS	LABOR RATE	LABOR DOLLARS	SUBCONTRACT DOLLARS	MISC. & RENTAL DOLLARS
1	Remove Ceilings	EA	\$100.00	\$100.00	48	48	\$71.40	\$3,427.20	\$0.00	
1	Replace Ceilings & cleanup	EA	\$250.00	\$250.00	64	64	\$71.40	\$4,569.60	\$0.00	
				\$0.00		0		\$0.00	\$0.00	
				\$0.00		0		\$0.00	\$0.00	
				\$0.00		0		\$0.00		
				\$0.00		0		\$0.00		
				\$0.00		0		\$0.00		
				\$0.00		0		\$0.00		
				\$0.00		0		\$0.00		
				\$0.00		0		\$0.00		
				\$0.00		0		\$0.00		
				\$0.00		0		\$0.00		
				\$0.00		0		\$0.00		
				\$0.00		0		\$0.00		
				\$0.00		0		\$0.00		
				\$0.00		0		\$0.00		
				\$0.00		0		\$0.00		
				\$0.00		0		\$0.00		
				\$0.00		0		\$0.00		
				\$0.00		0		\$0.00		
				\$350.00		112.00		\$7,996.80	\$0.00	\$0.00

NOTE: We have only included removing the first 2 tiles on each side of the corridor and the first 2 tiles on the classroom side of the corridor for only the 1963 wing area. Areas in the classroom will be protected with plastic prior to opening ceiling as there is existing debris laying on the tiles which will require cleanup.

 **AIA**[®] Document G709™ – 2018**Proposal Request****PROJECT:** *(name and address)*

Hebron Elem. School Contaminated Water
Piping Replacement
92 Church Street
Hebron CT 06248

CONTRACT INFORMATION:

Contract For: General Construction
Date: December 13, 2019

Architect's Project Number: 19.003

Proposal Request Number: 04

Proposal Request Date: June 5, 2020

OWNER: *(name and address)*

Town of Hebron
15 Gilead Street
Hebron CT 06248

ARCHITECT: *(name and address)*

Silver Petrucelli & Associates, Inc.
3190 Whitney Avenue
Hamden CT 06518

CONTRACTOR: *(name and address)*

The Nutmeg Companies, Inc.
1 Ohio Avenue
Norwich CT 06360

The Owner requests an itemized proposal for changes to the Contract Sum and Contract Time for proposed modifications to the Contract Documents described herein. The Contractor shall submit this proposal within Seven (7) days or notify the Architect in writing of the anticipated date of submission.

(Insert a detailed description of the proposed modifications to the Contract Documents and, if applicable, attach or reference specific exhibits.)

Provide a detailed Change Order Proposal for the added cost to temporarily remove, store, protect, and reinstall the suspended ceiling tiles in the corridors at Hebron ES and the first (3) rows of suspended ceiling tiles at the classroom/office side of the corridor walls as required to facilitate visual & physical access to both sides of the corridor wall construction above the ceilings to support Nutmeg's field survey & documentation of existing penetration violations through rated corridor wall construction under PR-05.

Attachments:

-None

THIS IS NOT A CHANGE ORDER, A CONSTRUCTION CHANGE DIRECTIVE, OR A DIRECTION TO PROCEED WITH THE WORK DESCRIBED IN THE PROPOSED MODIFICATIONS.

REQUESTED BY THE ARCHITECT:Ryan Haley, Project Manager**PRINTED NAME AND TITLE**

THE NUTMEG COMPANIES, INC.

PROPOSAL/ESTIMATE FOR CONTRACT MODIFICATION

CONTRACT TITLE: Hebron School Contaminated Water Piping Replacement
CONTRACT #
PCO #06 Replace Kitchen Faucets per PR#6

DATE: 6/30/2020
Rev Date:

DESCRIPTION OF PROPOSAL: Remove & replace kitchen faucets per PR#6

PRIME CONTRACTOR'S WORK			
1. Direct Materials		\$1,406.00	
2. Sales Tax on Materials 0 % of line 1	0.00%	\$0.00	
3. Direct Labor		\$1,568.88	
4. Misc. / Rental Equipment Crane / Lull Rental		\$0.00	
5. Sales Tax on Rental Equipment 6.35% of line 4	6.35%	\$0.00	
6. Equipment Ownership and Operating Expenses			
7. SUBTOTAL (add lines 1 - 6)			\$2,974.88
8. Field Overhead	0.00%		\$0.00
9. SUBTOTAL			\$2,974.88

Prime Remarks:

SUBCONTRACTOR'S WORK			
10. Subcontractor's work			\$0.00
11. Sub-contractors Bond Premium ___% of line 10	0.00%		\$0.00
12. SUBTOTAL			\$0.00

Sub's Remarks:

SUMMARY			
13. Prime Contractor's Work (from line 9)		\$2,974.88	
14. Not used		\$0.00	
15. Not Used		\$0.00	
16. Sub-contractor's Work (from line 12)		\$0.00	
17. SUBTOTAL (add lines 13, 14, 15 & 16)			\$2,974.88
18. Prime Overhead on Sub. 13.1.74% of line 16	5.00%	\$0.00	
19. Prime's Overhead 10% of line 13	10.00%	\$297.49	
20. Prime's Profit 5 % of line 17	5.00%	\$148.74	
21. SUBTOTAL (add lines 16, 17, 18, 19 & 20)			\$3,421.11
22. Prime Cont.'s Bond Premium	0.000%	\$0.00	
23. TOTAL COST (Add Lines 21 & 22)			3,421

Estimated time extension and justification:

Prime Contractor Name: THE NUTMEG COMPANIES, INC.

Evert Gawendo VP

Date: 6/30/2020

QTY	DESCRIPTION	Unit	UNIT	TOTAL	UNIT		LABOR	LABOR	SUBCONTRACT	MISC. & RENTAL
			MATERIAL	MATERIAL	HRS.	HOURS	RATE	DOLLARS	DOLLARS	DOLLARS
1	Change Kitchen Faucets	EA	\$1,406.00	\$1,406.00	18	18	\$87.16	\$1,568.88	\$0.00	
	per attached breakdown sheet	EA		\$0.00		0		\$0.00	\$0.00	
				\$0.00		0		\$0.00	\$0.00	
				\$0.00		0		\$0.00	\$0.00	
	NOTE: We have included adding a mixing valve at the hand sink location only as we believe this fixture should have one. It can be deleted if this is not the case.			\$0.00		0		\$0.00		
				\$0.00		0		\$0.00		
				\$0.00		0		\$0.00		
				\$0.00		0		\$0.00		
				\$0.00		0		\$0.00		
				\$0.00		0		\$0.00		
				\$0.00		0		\$0.00		
				\$0.00		0		\$0.00		
				\$0.00		0		\$0.00		
				\$0.00		0		\$0.00		
				\$0.00		0		\$0.00		
				\$0.00		0		\$0.00		
				\$0.00		0		\$0.00		
				\$0.00		0		\$0.00		
				\$0.00		0		\$0.00		
				\$0.00		0		\$0.00		
				\$0.00		0		\$0.00		
				\$0.00		0		\$0.00		
				\$1,406.00		18.00		\$1,568.88	\$0.00	\$0.00

ESTIMATE SHEET

JOB NAME HEBRON ELEMENTARY SCHOOL	ESTIMATE NO.
LOCATION HEBRON CT	ESTIMATOR JR
DATE 6/29/2020	
JOB DESCRIPTION RFI# 19 KITCHEN FAUCETS	

TAKE OFF	DESCRIPTION	QTY	LABOR UNIT	LABOR EXTENSION	MATERIAL PRICE	MATERIAL EXTENSION
HAND SINK	T-S BRASS FAUCET 5F-4WLX 03	1		4	101	101 ✓
FIXTURE STOPS RISERS		2			12 4.50	24 9 ✓
2 BAY SINK	T-S BRASS FAUCET B-0221	1		4	146	146 ✓
FIXTURE STOPS RISERS		2			12 4.50	24 9 ✓
3 BAY SINK	T-S BRASS FAUCETS B-0290	2		8	330	660 ✓
FIXTURE STOPS RISERS		4			12 4.50	48 18 ✓
HW-WARMING TRAY FAUCET	T-S BRASS B-0207	1		2	84	84 ✓
FIXTURE STOPS RISERS		2			12 4.50	24 9 ✓
	1/2" BRASS ST ELBOW	2			5.50	11 ✓
	1/2" X SP BRASS NIPPLES	2			3	6 ✓
	3/4" MALE x 1/2" COMPRESSION	4			7	28 ✓
MIX VLV	ACORN ST70-39	1			55	55 ✓
MISC	TAPE, DOPE, FERMCOS	1				150 ✓
				18		1406 ✓
	LABOR = 18 x 87.16 = 1568.88					
	MATERIAL = \$1406.00					
	1406 x					
SHEET TOTAL						

The Granite Group BR 41
1425 Gold Star Highway
Groton, CT 06340
(860)629-7620

Order #	12656271-00
Page #	1
Ship Point	The Granite Group BR 41
Via	PICK UP
Terms	ar 2%10thN30
Entered	06/29/20
Promised	06/29/20

Bill To: 7107
The Nutmeg Companies Inc.
1 Ohio Ave
Norwich, CT 06360

Ship To
Town of Hebron CT #067-0042
The Nutmeg Companies Inc.
92 Church Street
Hebron, CT 06248

Taken By rjp4 Sales in rjp4 Sales out JMB4 Placed by TAMMY MAGREY Customer P/O t/s faucets				Instructions MUST HAVE JOB NAME!!!	
---	--	--	--	--	--

Ln#	Product And Description	Qty Ordered	Qty B/O	Qty Shipped	Qty U/M	Unit Price	Price Unit	Amount (Net)
1	ts5f4w1x03 hand sink faucet	1		1	each	100.23	each	100.23
2	tsb0221 pantry faucet	1		1	each	145.13	each	145.13
3	tsb0290 3 bay sink faucets	2		2	each	329.79	each	659.58
4	tsb0270 warm tray faucet	1		1	each	83.57	each	83.57

4	Lines Total	Qty Shipped Total	5	Line Total	988.51
				Freight	38.57
				Invoice Total	1027.08

STOCK AT FACTORY
WOULD ALLOW FOR A WEEK TO REC.

6/30/2020

UNLESS NOTED ELSEWHERE, THIS QUOTE IS ONLY VALID FOR 30 DAYS FROM THE ENTERED DATE.

THIS CONTRACT IS GOVERNED BY AND SUBJECT TO THE GRANITE GROUP WHOLESALERS, LLC'S STANDARD 'TERMS AND CONDITIONS', LOCATED AT WWW.THEGRANITEGROUP.COM/TERMSANDCONDITIONS/. 'THE TERMS AND CONDITIONS' LOCATED AT WWW.THEGRANITEGROUP.COM/TERMSANDCONDITIONS/ ARE HEREBY INCORPORATED BY REFERENCE INTO THIS DOCUMENT. BY PURCHASING GOODS FROM THE GRANITE GROUP WHOLESALERS, LLC, YOU ACKNOWLEDGE YOU HAVE READ THE 'TERMS AND CONDITIONS' AND AGREE TO AND INTEND TO BE BOUND BY THE 'TERMS AND CONDITIONS' LOCATED AT WWW.THEGRANITEGROUP.COM/TERMSANDCONDITIONS/. BOTH PARTIES AGREE THAT THESE 'TERMS AND CONDITIONS' ARE SUBJECT TO CHANGE.

The **nutmeg companies, inc.**
~ **General Contractors** ~
1 Ohio Avenue
Norwich, CT 06360
www.nutmegcompanies.com
(860) 823-1780

SENT TO GRANITE FOR PRICING
11:00 AM
MONDAY 6/29/2020

RFI

To: Steven June
Silver/Petrucci Associates
3190 Whitney Ave.
Hamden, CT 06518
Ph: (203) 230-9007 Fax: (203) 230-8247

RFI #: 19
Date: 6/22/2020
Job #: 1910-00
Job Name: Hebron Elem School Piping Repl
Contract #: 067-0042 CV

CC:

Subject: Kitchen Faucet

Drawing: P-106 & P-108

Cost Impact: ?

Spec Section:
Schedule Impact: None

Request:

Date Required: 6/22/2020

It was brought to our attention by Mark Fitzgerald that there are existing faucets in the kitchen that we do not see where the plans call for their replacement. On drawings P-106 & P-108 we only see a new frost proof hose bib called for this area. There is one double pot sink with a single faucet, a triple pot sink with 2 faucets, a single hot only faucet for the warming tray and a small hand sink faucet for a total of 5. Please review & advise

Requested by: Evert Gawendo
THE NUTMEG COMPANIES, INC.

Response:

In a forthcoming Proposal Request, please replace the existing kitchen faucets with the following:

Hand Sink Faucet: T & S Brass # 5F-4WLX03

<https://www.tsbrass.com/p/equip-manual-faucets/5F-4WLX03>

2-Bay Sink Faucet: T & S Brass # B-0221

<https://www.tsbrass.com/p/pantry-faucets/B-0221>

3-Bay Sink Faucet: T & S Brass # B-0290 (Two are required)

<https://www.tsbrass.com/p/big-flo-faucets/B-0290>

Hot-only Warming Tray Faucet: T&S Brass # B-0207

<https://www.tsbrass.com/p/pantry-faucets/B-0207>

MBQ 6-26-2020

Answered by _____

Company _____

Date _____



Faucets

5F-4WLX03

TAG:

4" Wall Mount Faucet

Architect/Engineering Specifications:

4" wall mount mixing faucet with polished chrome plated brass body, 3" equip swivel gooseneck, ceramic cartridges, equip lever handles and 1/2" NPT male inlets. Certified to ASME A112.18.1\CSA B125.1, NSF 61-Section 9 and NSF 372. Meets ADA ANSINCC A117.1 requirements.

Job Name _____
 Model Specified _____ Quantity _____
 Variations Specified _____
 Date _____

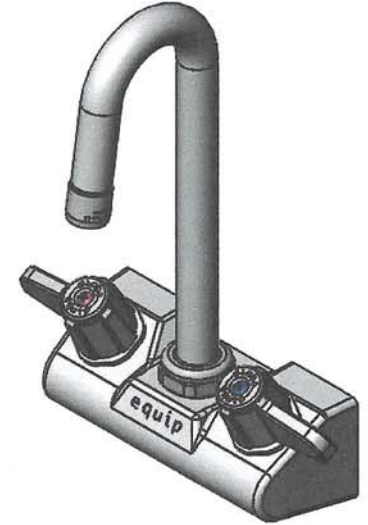
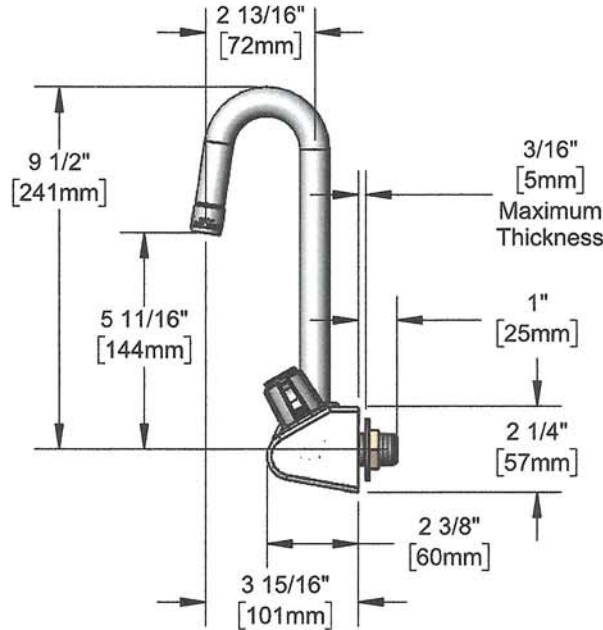
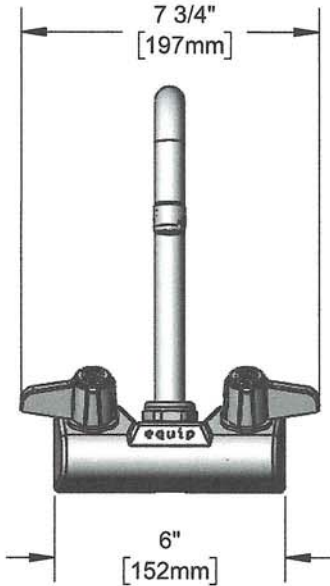

Features & Benefits:

- 4" wall mount mixing faucet w/ polished chrome plated brass body
- 3" swivel gooseneck w/ 2.2 GPM aerator
- Quarter-turn ceramic cartridges
- equip lever handles w/ color coded screws
- 1/2" NPT male inlets
- Material: Polished chrome plated brass body & chrome plated metal handles

Product Compliance:

- ASME A112.18.1 / CSA B125.1
- NSF 61 - Section 9
- NSF 372 (Low Lead Content)
- ANSI A117.1 (ADA)

Warranty: One Year (Limited)

Performance Data:

- Pressure: 20 - 125 psi
- Temperature: 40°F - 140°F
- Flow Rate: 2.2 GPM @ 60 psi



ADA Compliant



equip Foodservice Accessories



• 2 Saddleback Cove • Travelers Rest, SC 29690
Ph 800-891-4808 • Fax 800-868-0084
www.tsbrass.com

Date: 01/20/20



Swivel Sink and Pantry Faucets

TAG: _____

B-0221

Double Pantry Faucet

Architect/Engineering Specifications:

8" deck mount mixing faucet with polished chrome plated brass body, 12" swing nozzle with stream regulator outlet, compression cartridges with spring checks, lever handles and 1/2" NPT female inlets. Certified to ASME A112.18.1/CSA B125.1, NSF 61-Section 9 and NSF 372. Meets ADA ANSI/ICC A117.1 requirements.

Job Name _____
 Model Specified _____ Quantity _____
 Variations Specified _____
 Date _____

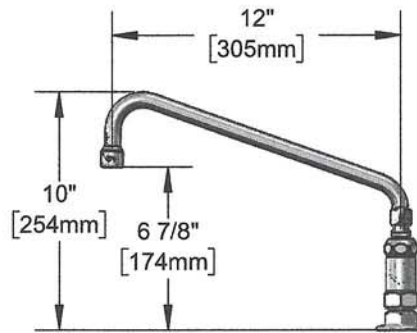
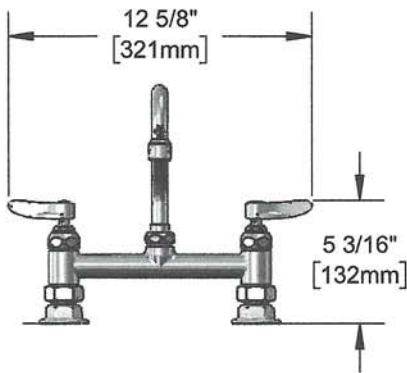

Features & Benefits:

- 8" deck mount mixing faucet with polished chrome plated brass body
- 12" swing nozzle
- Lock washer provided for rigid application
- Stream regulator outlet, Series 1
- Quarter-turn Eterna compression cartridges w/ spring checks to prevent the cross flow of water
- Lever handles w/ color coded indexes
- 1/2" NPT female eccentric inlets w/ Ø 2" flanges
- Adjustable centers from 7 3/4" to 8 1/4"
- Material: Polished chrome plated brass body & tubular spout and polished chrome plated metal handles

Product Compliance:

- ASME A112.18.1 / CSA B125.1
- NSF 61 - Section 9
- NSF 372 (Low Lead Content)
- ANSI A117.1 (ADA)



Warranty: One Year (Limited)

Performance Data:

- Pressure: 20 - 125 psi
- Temperature: 40°F - 140°F
- Flow Rate: 18.39 GPM @ 60 psi



Optional Outlets (Series 1 / VR Series 6)

GPM	Aerated	Non-Aerated (Laminar)	VR Aerated	VR Non-Aerated (VR Laminar)
0.35	N/A	<input type="checkbox"/> B-0199-01-N035	N/A	<input type="checkbox"/> B-0199-06-N035
0.5	N/A	<input type="checkbox"/> B-0199-01-N05	N/A	<input type="checkbox"/> B-0199-06-N05
1.0	<input type="checkbox"/> B-0199-01-F10	N/A	<input type="checkbox"/> B-0199-06-F10	N/A
1.2	<input type="checkbox"/> B-0199-01-F12	<input type="checkbox"/> B-0199-01-LF12	<input type="checkbox"/> B-0199-06-F12	<input type="checkbox"/> B-0199-06-LF12
1.5	<input type="checkbox"/> B-0199-01-WS	<input type="checkbox"/> B-0199-29	<input type="checkbox"/> B-0199-06-WS	<input type="checkbox"/> B-0199-29VR
2.2	<input type="checkbox"/> B-0199-01	<input type="checkbox"/> B-0199-21	<input type="checkbox"/> B-0199-06	<input type="checkbox"/> B-0199-21-VRF

Optional Handles

- 4" Wrist Action
- Lever (Standard)
- 4-Arm

Optional Cartridges With Checks

- Quarter-Turn Cerama w/ Check Valve
- Quarter-Turn Eterna w/ Spring Check (Standard)



T&S BRASS AND BRONZE WORKS, INC.



• 2 Saddleback Cove • Travelers Rest, SC 29690
 Ph 800-476-4103 • Fax 864-834-3518
 • Simi Valley, CA • Ph 800-423-0150 • www.tsbrass.com

Date: 05/01/18



Architect/Engineering Specifications:

8" wall mount large flow mixing faucet with polished chrome plated brass body, 12" plain end swing nozzle, compression spindles, 4-arm handles, 3/4" NPT female inlets and 3/4" NPT female short inlet elbows. Certified to ASME A112.18.1/CSA B125.1, NSF 61-Section 9 and NSF 372. Meets ADA ANSI/ICC A117.1 requirements.

Job Name _____
 Model Specified _____ Quantity _____
 Variations Specified _____
 Date _____

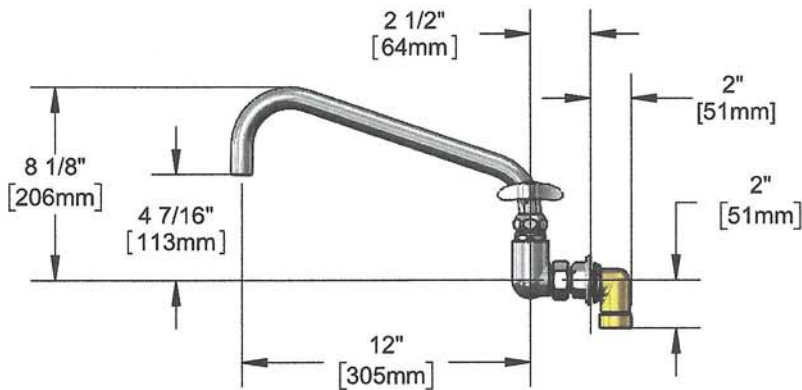
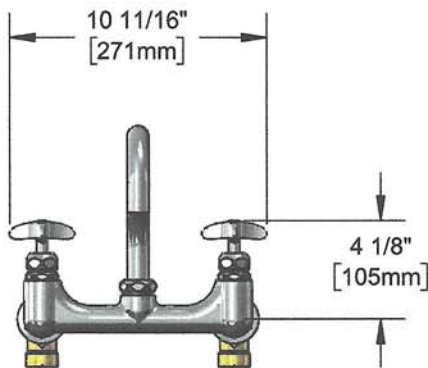

Features & Benefits:

- 8" wall mount Big-Flo mixing faucet w/ polished chrome plated brass body
- 12" Big-Flo plain end swing nozzle
- Lock washer provided for rigid application
- Big-Flo compression spindles
- 4-arm handles w/ color coded indexes
- 3/4" NPT female eccentric flanged inlets w/ Ø 2" flanges
- Adjustable centers from 7 3/4" to 8 1/4"
- 3/4" NPT female short inlet elbows
- Material: Polished chrome plated brass body & tubular spout and chrome plated metal handles

Product Compliance:

- ASME A112.18.1 / CSA B125.1
- NSF 61 - Section 9
- NSF 372 (Low Lead Content)
- ANSI A117.1 (ADA)

Warranty: One Year (Limited)

Performance Data:

- Pressure: 20 - 125 psi
- Temperature: 40 °F - 140 °F
- Flow Rate: 44.27 GPM @ 60 psi





Swivel Sink and Pantry Faucets

B-0270

TAG: _____

Double Pantry Faucet

Architect/Engineering Specifications:

Single hole deck mount mixing faucet with polished chrome plated brass body, 18" swing nozzle with stream regulator outlet, compression cartridges with spring checks, lever handles, 18" riser and 18" flexible stainless steel supply hoses with 1/2" NPSM / 5/8" compression connections. Certified to ASME A112.18.1 / CSA B125.1, NSF 61-Section 9 and NSF 372. Meets ADA ANSI/ICC A117.1 requirements.

Job Name _____
Model Specified _____ Quantity _____
Variations Specified _____
Date _____

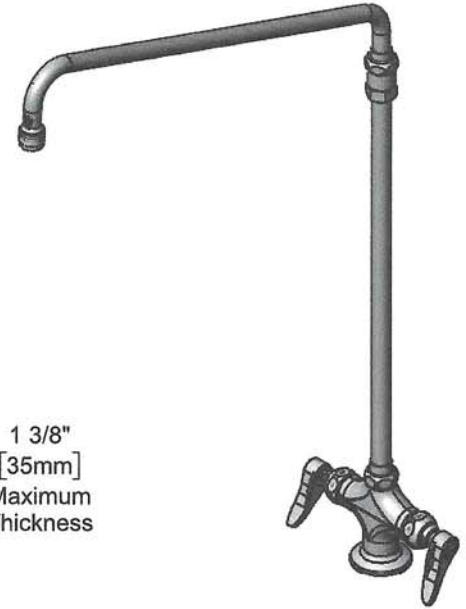
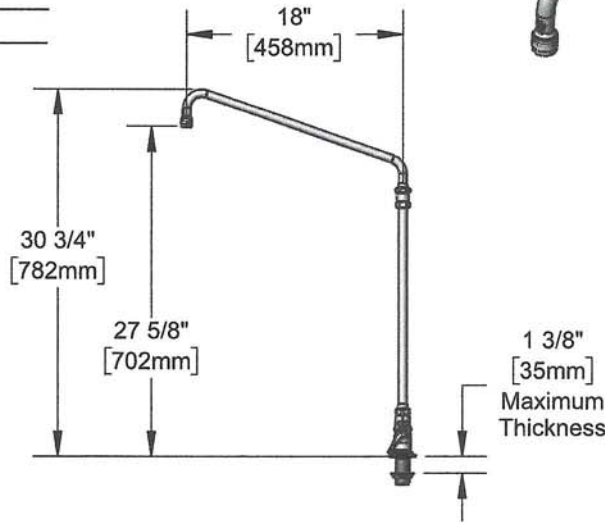
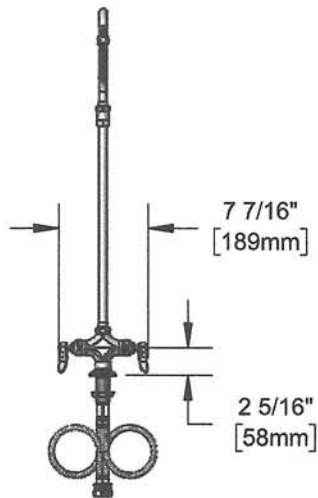

Features & Benefits:

- Single hole deck mount mixing faucet w/ polished chrome plated brass body
- 18" swing nozzle
- Stream regulator outlet, Series 1
- Quarter-turn Eterna compression cartridges with spring checks to prevent cross flow of water
- Lever handles w/ color coded indexes
- 18" riser
- 18" flexible stainless steel supply hoses with 1/2" NPSM / 5/8" compression connections
- Material: Polished chrome plated brass body, riser & tubular spout, polished chrome metal handles

Product Compliance:

- ASME A112.18.1 / CSA B125.1
- NSF 61 - Section 9
- NSF 372 (Low Lead Content)
- ANSI A117.1 (ADA)

Warranty: One Year (Limited)

Performance Data:

- Pressure: 20 - 125 psi
- Temperature: 40 °F - 140 °F
- Flow Rate: 9.10 GPM @ 60 psi



Optional Outlets (Series 1 / VR Series 6)

GPM	Aerated	Non-Aerated (Laminar)	VR Aerated	VR Non-Aerated (VR Laminar)	Optional Handles
0.35	N/A	<input type="checkbox"/> B-0199-01-N035	N/A	<input type="checkbox"/> B-0199-06-N035	<input type="checkbox"/> 4" Wrist Action
0.5	N/A	<input type="checkbox"/> B-0199-01-N05	N/A	<input type="checkbox"/> B-0199-06-N05	<input type="checkbox"/> Lever (Standard)
1.0	<input type="checkbox"/> B-0199-01-F10	N/A	<input type="checkbox"/> B-0199-06-F10	N/A	<input type="checkbox"/> 4-Arm
1.2	<input type="checkbox"/> B-0199-01-F12	<input type="checkbox"/> B-0199-01-LF12	<input type="checkbox"/> B-0199-06-F12	<input type="checkbox"/> B-0199-06-LF12	
1.5	<input type="checkbox"/> B-0199-01-WS	<input type="checkbox"/> B-0199-29	<input type="checkbox"/> B-0199-06-WS	<input type="checkbox"/> B-0199-29VR	Optional Cartridges
2.2	<input type="checkbox"/> B-0199-01	<input type="checkbox"/> B-0199-21	<input type="checkbox"/> B-0199-06	<input type="checkbox"/> B-0199-21-VRF	<input type="checkbox"/> Quarter-Turn Cerama w/ Check Valves
					<input type="checkbox"/> Quarter-Turn Eterna w/ Spring Checks (Standard)



T&S BRASS AND BRONZE WORKS, INC.



• 2 Saddleback Cove • Travelers Rest, SC 29690
Ph 800-476-4103 • Fax 864-834-3518
• Simi Valley, CA • Ph 800-423-0150 • www.tsbrass.com

Date: 05/05/17

July 2, 2020

Mark M. FitzGerald Construction LLC
MMFC LLC
21 Vanderpoel Ave.
Bantam, CT 06750

Clerk of the Work Services for:
Town of Hebron
Hebron Elementary School Drinking Water Remediation Project # 067-0042 CV
Invoice #6

June 15, 2020 – July 2, 2020

6/15/2020	Clerk Services	6:30-12:30	6 hrs.
	Conference Call	6:30-8:30PM	2 hr.
6/16/2020	Clerk Services	6:30-12:30	6 hrs.
	Email for SPA Review	6:00 -7:30 PM	1.5 hrs
6/17/2020	Clerk Services	6:30-12:30	6 hrs.
6/18/2020	Clerk Services	6:30-12:30	6 hrs.
	Report/pictures/email	6:30 -7:30	1 hr.
6/22/2020	Clerk Services	6:30 -12:30	6 hrs.
6/23/2020	Clerk Services	6:30-12:30	6 hrs.
6/24/2020	Clerk Services	6:30-12:30	6 hrs.
6/25/2020	Clerk Services	6:30-12:30	6 hrs.
	Report/pictures/email	3:30 -4:30	1 hr.
6/29/2020	Clerk Services	6:30-12:30	6 hrs.
6/30/2020	Clerk Services	6:30-12:30	6 hrs.
7/1/2020	Clerk Services	6:30-12:30	6 hrs.
7/2/2020	Clerk Services	6:30-12:30	6 hrs.
	Report/pictures/email	3:00-4:00	1 hr.

Regular Hours Billed 6/15/20- 7/2/20 75 @ \$113.00 \$ 8,475.00

Premium Hours Billed 6/15/20- 7/2/20 3.5 hrs @ \$145.00 \$ 507.50

Total Bill for Services Rendered: Project # 6/15/20- 7/2/20 \$ 8,982.50

Hungerfords Incorporated

Pump Service

PO Box 748
 North Haven, CT 06473-0748
 Phone (203)248-5541 Fax (203) 230-4799
 www.HungerfordsPumpService.com

SERVICE INVOICE

Date	Invoice #
6/22/2020	86775

CT Lic# P1-0204646

Bill To:

Hebron Board of Education
 580 Gilead Street
 Hebron, CT 06248

Service Site:

Hebron Elementary
 92 Church Street
 Hebron, CT

Service Date	P.O. Number	Terms	Due Date	Rep	Account #	Project
6/17/2020		NET	6/22/2020	BR		
Description			Quantity	Serviced	Price Each	Amount
Commercial Service Billing Open Hydro tank and work with CorrTech on evaluation. Removed cover from pressure tank for it to be cleaned. Reinstalled cover with new gasket. Also chlorinate tank and waited for it to fill up.						575.00 0.00
					Subtotal	\$575.00
					Sales Tax (0.0%)	\$0.00
					Total	\$575.00
				Payments/Credits	\$0.00	Balance Due \$575.00

TO OWNER: Town of Hebron
 15 Gilead Street
 Hebron, Connecticut 06248
 Attn: Rosalie Bouchard

PROJECT : Hebron Elementary School - Contaminated
 Water Piping Replacement
 92 Church Street, Hebron, CT 06248
 Via Architect: Silver / Petrucelli & Associates, Inc.
 3190 Whitney Avenue, Bldg.2
 Hamden, CT 06518

APPLICATION NO : 04
 PERIOD TO : 6/30/2020
 PROJECT NO : 1910-00
 CONTRACT DATE : 12/13/2019
 STATE PROJECT #: 067-0042 CV

Distribution to :
 OWNER [X]
 ARCHITECT [X]
 CONTRACTOR [X]

ATTN: Evert Gawendo-Vice President evert@nutmegcompanies.com

CONTRACT FOR: Hebron Elementary School - Contaminated Water Piping Replacement

TIN: 06-1236809

CONTRACTOR'S APPLICATION FOR PAYMENT

Application is made for payment, as shown below, in connection with the Contract.
 Continuation Sheet, AIA Document G703, is attached.

- 1. ORIGINAL CONTRACT SUM..... \$907,600.00
- 2. Net Change by Change Orders..... \$3,226.39
- 3. CONTRACT SUM TO DATE (Line 1 + 2)..... \$910,826.39
- 4. TOTAL COMPLETED & STORED TO DATE..... \$792,622.00
 (Column G on G703)
- 5. RETAINAGE :
 - a. 7.0 % of Completed Work \$55,483.54
 (Columns D + E on G703)
 - b. 7.0 % of Stored Material \$0.00
 (Column F on G703)
 - Total Retainage (Line 5a + 5b or
 Total in Column I of G703)..... \$55,483.54
- 6. TOTAL EARNED LESS RETAINAGE..... \$737,138.46
 (Line 4 less Line 5 Total)
- 7. LESS PREVIOUS CERTIFICATES FOR PAYMENT \$545,248.77
 (Line 6 from prior Certificate).....
- 8. CURRENT PAYMENT DUE..... \$191,889.69
- 9. BALANCE TO FINISH, INCLUDING RETAINAGE \$173,687.93
 (Line 3 less Line 6)

CHANGE ORDER SUMMARY	ADDITIONS	DEDUCTIONS
Total Changes approved in previous months by Owner	-	-
Total approved this Month	3,226.39	-
TOTAL	3,226.39	-
NET CHANGES by Change Order	3,226.39	-

The undersigned Contractor certifies that to the best of the Contractor's knowledge, information and belief the Work covered by this Application for Payment has been completed in accordance with the Contract Documents, that all amounts have been paid by the Contractor for Work for which previous Certificates for Payment were issued and payments received from the Owner, and that current payment shown herein is now due.

CONTRACTOR: The Nutmeg Companies, Inc.

By:  CFO Date: July 6, 2020
 James E. Sawyer, CFO

State of : Connecticut
 County of : New London
 Subscribed and sworn to before me this 6th day of July 2020

Notary Public: 
 My Commission expires : 7/13/23

ARCHITECT'S CERTIFICATE FOR PAYMENT

In accordance with the Contract Documents, based on on-site observations and the data comprising this application, the Architect certifies to the Owner that to the best of the Architect's knowledge, information and belief the Work has progressed as indicated, the quality of the Work is in accordance with the Contract Documents, and the Contractor is entitled to payment of the AMOUNT CERTIFIED.

AMOUNT CERTIFIED.....\$ \$191,889.69

(Attach explanation if amount certified differs from the amount applied for Initial all figures on this Application and on the Continuation Sheet that are changed to conform to the amount certified).

ARCHITECT: 
 By: _____ Date: 7/6/20

This certificate is not negotiable. The AMOUNT CERTIFIED is payable only to the contractor named herein. Issuance, payment and acceptance of payment are without prejudice to any rights of the Owner or Contractor under this Contract.

CONTINUATION SHEET

AIA DOCUMENT G703

AIA Document G702, APPLICATION AND CERTIFICATION FOR PAYMENT, containing Contractor's signed certification is attached.
 In tabulations below, amounts are stated to the nearest dollar.
 Use Column I on Contracts where variable retainage for line items may apply.

Via Architect: Silver / Petrucelli & Associates, Inc.
 3190 Whitney Avenue, Bldg.2
 Hamden, CT 06518
 Days added by Modification

APPLICATION NO: 1 04
 APPLICATION DATE: 30-Jun-20
 PERIOD TO: 30-Jun-20
 CONTRACT DATE: 12/13/19
 STATE PROJECT #: 067-0042 CV

A ITEM NO.	B DESCRIPTION OF WORK	C SCHEDULED VALUE	D WORK COMPLETED		F MATERIALS PRESENTLY STORED (NOT IN)	G		H BALANCE TO FINISH (C - G)
			FROM PREVIOUS APPLICATION (D+E)	THIS PERIOD		TOTAL COMPLETED AND STORED TO DATE (D+E+F)	% (G + C)	
1	<u>DIVISION-1 GENERAL CONDITIONS</u>							
2	BOND	9,872.00	9,872.00	-	-	9,872.00	100.00%	-
3								
4	<u>DIVISION-2 DEMO</u>							
5	REMOVE/REPLACE CEILINGS-LABOR	20,000.00	16,000.00	-	-	16,000.00	80.00%	4,000.00
6	DEMO/LEAD ABATEMENT-LABOR	52,000.00	-	52,000.00	-	52,000.00	100.00%	-
7								
8	<u>DIVISION 4-MASONRY</u>							
9	MASONRY-MATERIAL	9,000.00	900.00	3,600.00	-	4,500.00	50.00%	4,500.00
10	MASONRY-LABOR	9,000.00	900.00	2,600.00	-	3,500.00	38.89%	5,500.00
11								
12	<u>DIVISION 6-WOOD AND PLASTICS</u>							
13	MILLWORK-MATERIAL	1,000.00	-	-	-	-	0.00%	1,000.00
14	MILLWORK-LABOR	1,000.00	-	-	-	-	0.00%	1,000.00
15								
16	<u>DIVISION 9-FINISHES</u>							
17	GYPHUM -MATERIAL	2,500.00	-	-	-	-	0.00%	2,500.00
18	GYPHUM -LABOR	2,500.00	-	-	-	-	0.00%	2,500.00
19	CERAMIC TILE-MATERIAL	5,000.00	-	-	-	-	0.00%	5,000.00
20	CERAMIC TILE-LABOR	5,000.00	-	-	-	-	0.00%	5,000.00
21	PAINING-MATERIAL	2,500.00	250.00	-	-	250.00	10.00%	2,250.00
22	PAINING-LABOR	2,500.00	250.00	-	-	250.00	10.00%	2,250.00
23								
24	<u>DIVISION 10-SPECIALTIES</u>							
25	REMOVE TOILET PARTITIONS-LABOR	1,500.00	-	1,500.00	-	1,500.00	100.00%	-
26	REINSTALL EXISTING TOILET PARTITIONS-LABOR	1,500.00	-	-	-	-	0.00%	1,500.00
27	TOILET ACCESSORIES-MATERIAL	750.00	-	-	-	-	0.00%	750.00
28	TOILET ACCESSORIES-LABOR	750.00	-	-	-	-	0.00%	750.00
29								
30	<u>DIVISION 13-INSTITUTIONAL COVER</u>							
31	METAL PIPE COVER-MATERIAL	20,000.00	-	20,000.00	-	20,000.00	100.00%	-
32	METAL PIPE COVER-LABOR	10,000.00	-	6,000.00	-	6,000.00	60.00%	4,000.00
33								
34	<u>DIVISION 23-PLUMBING</u>							
35	PLUMBING DEMO-LABOR	25,000.00	2,500.00	21,250.00	-	23,750.00	95.00%	1,250.00
36	PLUMBING INSULATION-MATERIAL	19,000.00	15,000.00	2,000.00	-	17,000.00	89.47%	2,000.00
37	PLUMBING INSULATION-LABOR	19,000.00	14,500.00	1,500.00	-	16,000.00	84.21%	3,000.00
38								

CONTINUATION SHEET

AIA DOCUMENT G703

AIA Document G702, APPLICATION AND CERTIFICATION FOR PAYMENT, containing Contractor's signed certification is attached.
 In tabulations below, amounts are stated to the nearest dollar.
 Use Column I on Contracts where variable retainage for line items may apply.

Via Architect: Silver / Petrucelli & Associates, Inc.
 3190 Whitney Avenue, Bldg.2
 Hamden, CT 06518
 Days added by Modification

APPLICATION NO: 1 04
 APPLICATION DATE: 30-Jun-20
 PERIOD TO: 30-Jun-20
 CONTRACT DATE: 12/13/19
 STATE PROJECT #: 067-0042 CV

A ITEM NO.	B DESCRIPTION OF WORK	C SCHEDULED VALUE	D WORK COMPLETED		F MATERIALS PRESENTLY STORED (NOT IN	G		H BALANCE TO FINISH (C - G)
			FROM PREVIOUS APPLICATION (D+E)	THIS PERIOD		TOTAL COMPLETED AND STORED TO DATE (D+E+F)	% (G + C)	
39	PIPE HANGERS-MATERIAL	106,000.00	95,000.00	9,000.00	-	104,000.00	98.11%	2,000.00
40	PIPE HANGERS-LABOR	140,000.00	115,000.00	18,000.00	-	133,000.00	95.00%	7,000.00
41	DOMESTIC WATER PIPING-MATERIAL	125,573.00	110,000.00	10,000.00	-	120,000.00	95.56%	5,573.00
42	DOMESTIC WATER PIPING-LABOR	150,000.00	125,000.00	10,000.00	-	135,000.00	90.00%	15,000.00
43	PLUMBING FIXTURES-MATERIAL	95,000.00	65,000.00	20,000.00	-	85,000.00	89.47%	10,000.00
44	PLUMBING FIXTURES-LABOR	15,000.00	5,000.00	-	-	5,000.00	33.33%	10,000.00
45	WATER HEATERS-MATERIAL	20,000.00	6,667.00	11,333.00	-	18,000.00	90.00%	2,000.00
46	WATER HEATERS-LABOR	5,000.00	1,000.00	1,500.00	-	2,500.00	50.00%	2,500.00
47	GAS PIPING-MATERIAL	1,500.00	-	-	-	-	0.00%	1,500.00
48	GAS PIPING-LABOR	1,000.00	-	-	-	-	0.00%	1,000.00
49	WATER HEATER BREECHING-MATERIAL	6,000.00	-	4,000.00	-	4,000.00	66.67%	2,000.00
50	WATER HEATER BREECHING-LABOR	2,655.00	-	1,000.00	-	1,000.00	37.66%	1,655.00
51								
52	<u>DIVISION 26-ELECTRICAL</u>							
53	ELECTRICAL DEMO-LABOR	4,500.00	450.00	4,050.00	-	4,500.00	100.00%	-
54	WIRE-MATERIAL	3,000.00	1,500.00	1,000.00	-	2,500.00	83.33%	500.00
55	WIRE-LABOR	3,000.00	1,500.00	1,000.00	-	2,500.00	83.33%	500.00
56	WIRE FLUSH VALVE TRANSFORMERS-MATERIAL	4,000.00	-	2,000.00	-	2,000.00	50.00%	2,000.00
57	WIRE FLUSH VALVE TRANSFORMERS-LABOR	4,000.00	-	2,000.00	-	2,000.00	50.00%	2,000.00
58	DISCONNECT WASHSINKS-LABOR	1,000.00	-	1,000.00	-	1,000.00	100.00%	-
59	RECONNECT WASHSINKS-LABOR	1,000.00	-	-	-	-	0.00%	1,000.00
60								
61	ORIGINAL CONTRACT SUM	907,600.00	586,289.00	206,333.00	-	792,622.00	87.33%	114,978.00
62								
63	CHANGE ORDERS							
64	Change Order #001							
65	PCO #1R - ADDED WATER SAMPLING FAUCETS	1,129.32	-	-	-	-	0.00%	1,129.32
66	PCO #2R - MIXING VALVE ENCLOSURE CREDIT	(1,474.32)	-	-	-	-	0.00%	(1,474.32)
67	PCO #3R - ADD DF AT CLASSROOM #93	1,051.65	-	-	-	-	0.00%	1,051.65
68	PCO #4R - REPLACE CRACKED FIXURES	2,519.74	-	-	-	-	0.00%	2,519.74
69								
70								
71	TOTAL CHANGE ORDERS	3,226.39	-	-	-	-		3,226.39
72								
73								
74	GRAND TOTALS	910,826.39	586,289.00	206,333.00	-	792,622.00	87.02%	118,204.39